



TYPICAL CONFIGURATIONS V5
Two Wire Start/Stop with Remote Reset and Bypass/Power Factor Contactor Control

S/W version 2.1

Created: **B.Sheridan**
Position: **Technical Director**
Date: **14/07/04**

Reviewed: **M. Duncan**
Position: **Sales and Marketing Director**
Date: **14/07/04**

TYPICAL CONFIGURATIONS V5

Two Wire Start/Stop with Remote Reset and Bypass/Power Factor Contactor Control.

1.- Configuration Parameters

CODE	DESCRIPTION	DISPLAY	VALUE (DEFAULT)
NAMEPLATE			
G2.1	Soft Starter Current	I Starter	(Rated nameplate current of soft starter)
G2.2	Motor Current	I Motor	(Auto dependant on V5 model) Adjust to motor nameplate FLC
G2.3	Motor Voltage	V Motor	(380V/440V)
G2.4	Motor Power	P Motor	(11) Adjust to motor nameplate Power
G2.5	Motor Cosinus Phi	Cos Phi M	(85%) Adjust to motor nameplate Power Factor
G2.6	Supply Frequency	Freq	(50Hz)
PROTECTIONS			
G3.1	Phase Sequence	Phase Sequen	(L1, L2, L3 Seq)
G3.2	Overload Motor Current	Overload	(Auto dependant on V5 model) Adjust to motor nameplate FLC
G3.3	Overload Curve	O/load Curve	(5)
G3.4	Starting Overload Factor	Oload Factor	(100%)
G3.5	Motor PTC	Motor PTC	(No)
ACCELERATION			
G4.1	Start Delay	Str Delay	(0)
G4.2	Torque Pulse	Puls Torq	(50%)
G4.3	Torque Pulse Time	Pulse Tq T	(Off)
G4.4	Initial Torque	Init Torque	(35%). Adjust to suit load requirements. Pumps and low inertia loads typically 40%~45%. Higher inertia loads may be between 45% ~80%
G4.5	Initial Torque Time	Init Tq T	(1s)
G4.6	Acceleration Time	Acel Time	(6s) Adjust to suit application requirements
G4.7	Current Limit	I Limit	(3 * In of V5 model). Set to load requirements. Typically between 300% and 450% of motor FLC
DECELERATION			
G5.1	Freewheel Stop	Frewel Stp	(Yes). Set to No for ramped stop
G5.2	Deceleration time	Decl Time	(12). Set to load requirements.
INPUTS			
G6.1	Control Mode	Oper Mode	(0). Set to 2 for control from digital inputs
G6.2	Local Reset	Local Reset	(Y)
G6.3	Digital Input 1	D Input1 Sel	(0). Set to 4 for 2 wire start/stop
G6.4	Digital Input 2	D Input2 Sel	(0). Set to 5 for reset
OUTPUTS			
G7.1	Relay Output 1	Rel1 Sel On	(14) Instantaneous
G7.2	Relay Output 2	Rel2 Sel On	(15) Bypass/React. Suitable for Bypass or Power Factor contactor control

denotes minimum necessary adjustments.

2.- Control terminal connections.

Inputs

Terminal 10 : Common
 Terminal 11 : Programmable digital input 1 (set to Mode 04 = Start/Stop)
 Terminal 12 : Programmable digital input 2 (set to Mode 05 = Reset)

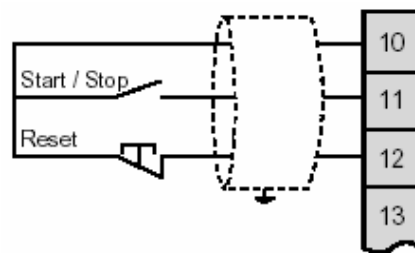

Outputs

Terminal 4 : Relay NO Contact
 Terminal 5 : Relay Common Contact

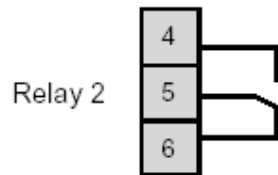

TYPICAL CONFIGURATIONS V5

Power Connections

- By-pass configuration.

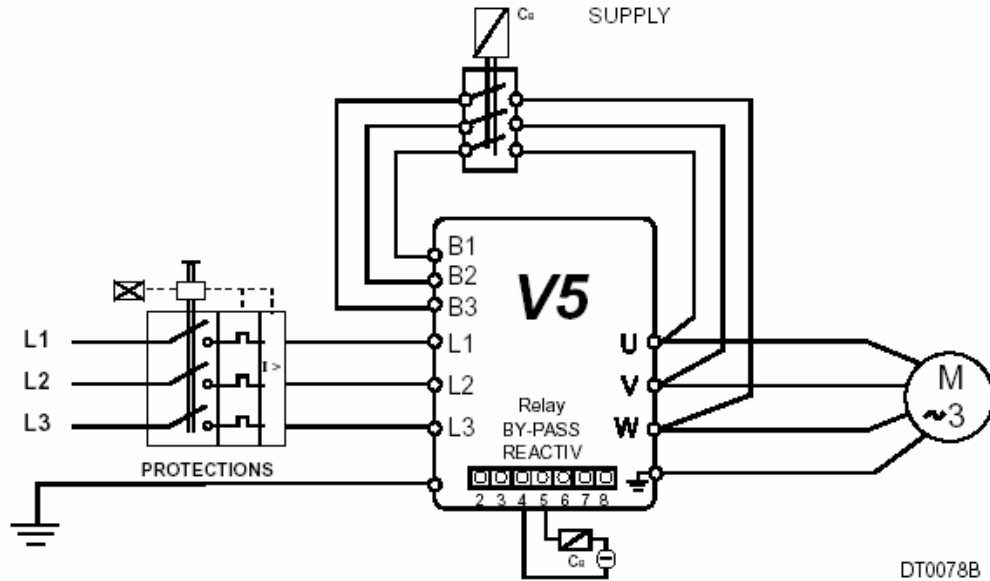

- Configuration for compensation capacitors.

